

# RHODaS PROJECT FINAL RESULTS

**Objectives, Key Results, and  
Impact for Heavy-Duty Transport**

**Piotr Bielaczyc & Rafal Sala – BOSMAL  
Automotive R&D Institute Ltd, Poland**

**Luis Romeral & David Lumbreras Carrasco –  
Universitat Politècnica de Catalunya, Spain**



With the support of



This project has received funding from the European Union's Horizon Europe research and innovation programme under grant agreement No. XXX

# Overall project presentation



# CONSORTIUM

## COORDINATOR



## BUDGET

€ 5,956,938.00

## PARTICIPANTS



# PROJECT OBJECTIVES & TARGETS

**TO1.** Improve efficiency and performance of power converters while increasing affordability of powertrains for heavy-duty Evs

40% reduction of termal losses, temperature operation up to 175°C, truck driving range + 10%

**TO2.** Reduce size and weight of the power converters

50% reduction of size,  
30% reduction of weight,  
15 dB reduction of EMI noise

**TO3.** Effective application of digital technologies and sensors for advanced on-line monitoring and intelligent estimation and prediction of states based in advanced modelling and prediction techniques using Big Data Analysis and Artificial Intelligence

30% reduction of failures,  
20% reduction of costs,  
25% extensión of lifetime

**TO4.** Effective integration of the power electronics and TMS in a modular and compact IMD to evaluate the overall performance in a complete e-axel test bench

IMD efficiency increase >5%,  
RUL prediction accuracy >75%;  
75% reduction in converter losses

**TO5.** Integration of eco-design, material criticality and circularity considerations into the RHODaS powertrain solution, as well as viable circular business models for their future commercialization

25% extension of life, 30% improvement in environmental and circular performance

**TO6.** Promote collaborative research and interaction between academia and industry throughout the entire supply chain

8 networking events

# Results presentation



# EFFICIENT POWER CONVERTER DESIGN

## HYBRID T-TYPE MULTILEVEL TOPOLOGY

- **Architecture:** Combines 1200V SiC and 650V GaN switches.
- **Benefit:** Maximizes efficiency while reducing passive component size.
- **Thermal Management:** Optimized heatsink design using CFD sensitivity analysis for uniform cooling.
- **Modulation:** Validated SVPWM & CB-PWM algorithms with adaptive level-shifting.

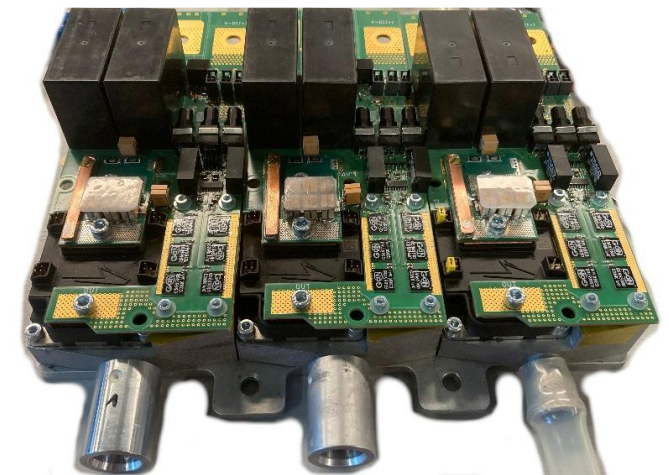
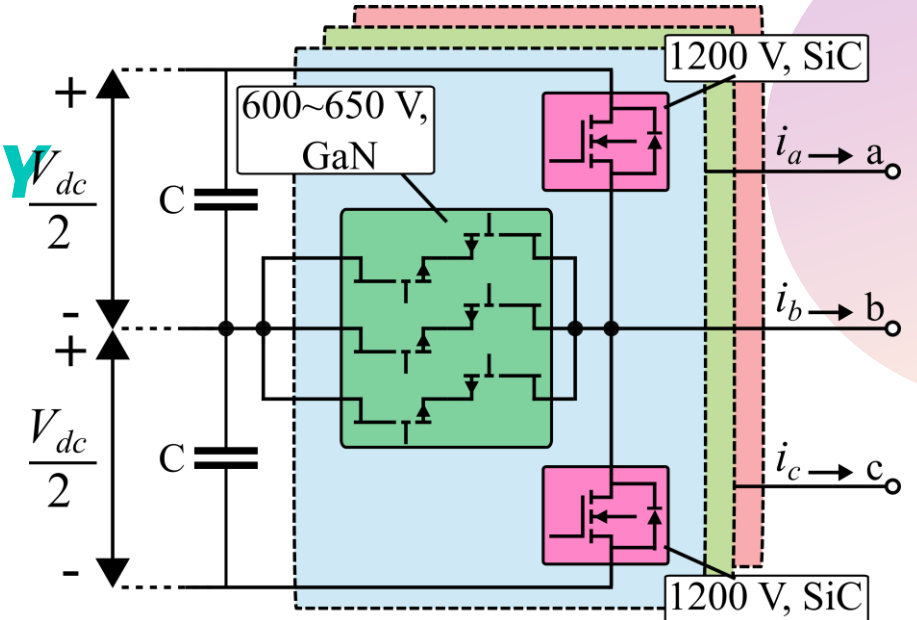

# CLOUD-BASED ARCHITECTURE & DIGITAL TOOLS



## **3-LEVEL ARCHITECTURE**

*Integration between the Converter ECU (Local), On-board Gateway (Edge), and Microsoft Azure (Cloud).*



## **FAULT TOLERANCE**

*Dynamic reconfiguration logic: System automatically switches from 3-Level to 2-Level mode upon failure, ensuring vehicle availability.*



## **DECISSION SUPPORT**

*AI-driven Decision Support System (DSS) using edge sensors for vibration analysis and predictive maintenance.*

# DIGITAL TWIN & IOT PLATFORM

## VIRTUAL SENSING & MONITORING

The project developed a comprehensive Digital Twin that includes thermal models for the Power Converter, E-Motor, and Gearbox.

### Key Features:

- Estimation of junction temperatures where physical sensors cannot reach.
- Real-time data visualization via a web dashboard.
- Integration with DSS for early fault detection.

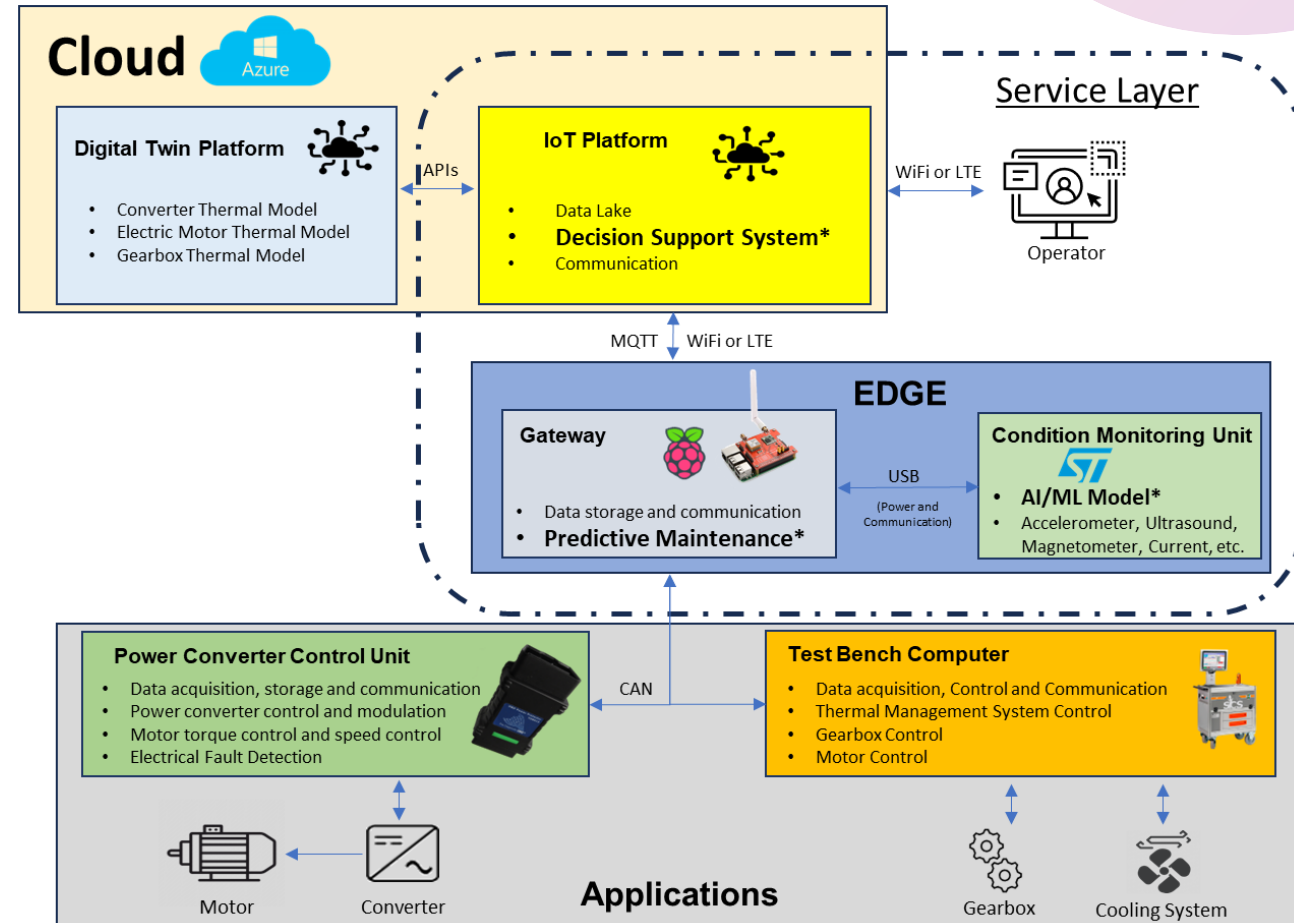

# IMD INTEGRATION & VALIDATION

## Validation

*The modular IMD underwent rigorous testing at BOSMAL test facilities.*

- *Run-in Tests*
- *Efficiency Mapping: Measured based on ISO 21782-3 standards.*
- *Thermal Rise*
- *Limit Operation: Max net power characterization per ECE-R85.*

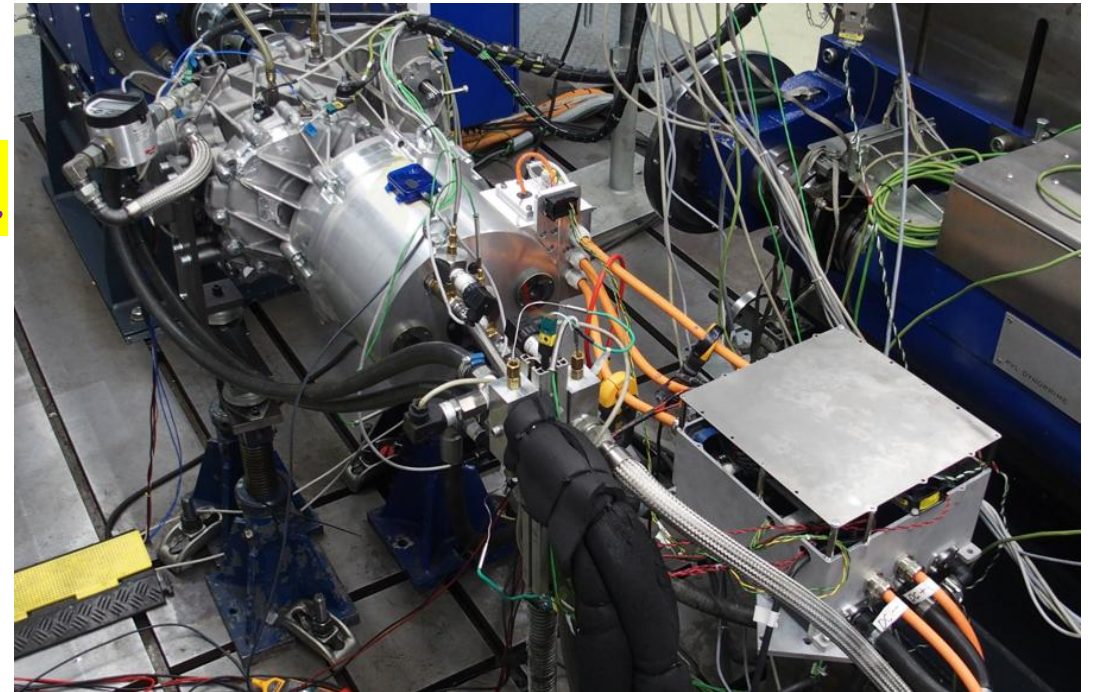

# IMD INTEGRATION & VALIDATION

**Validation** The modular IMD underwent rigorous testing at BOSMAL test facilities

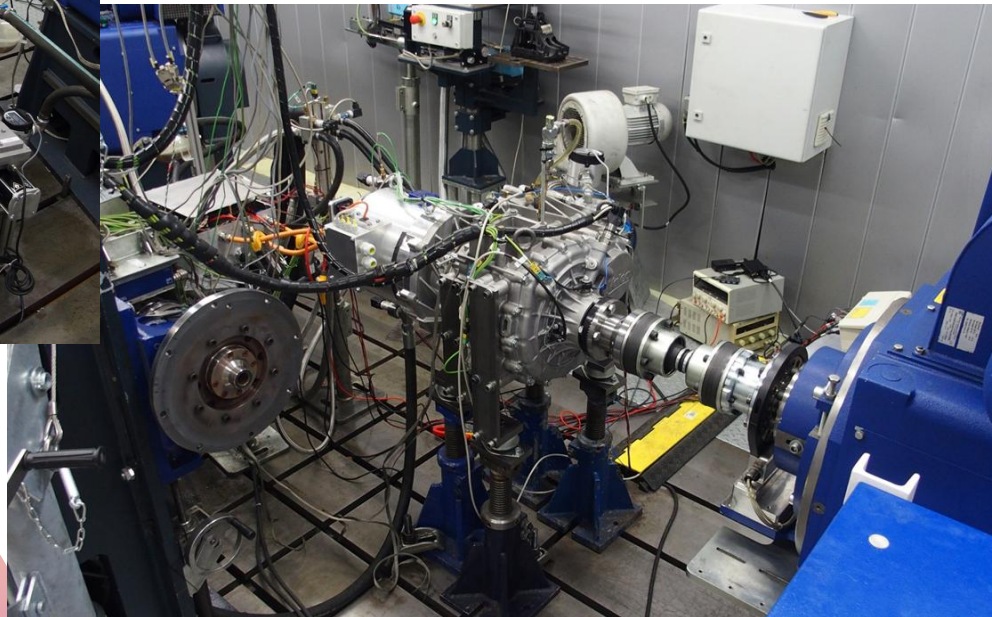
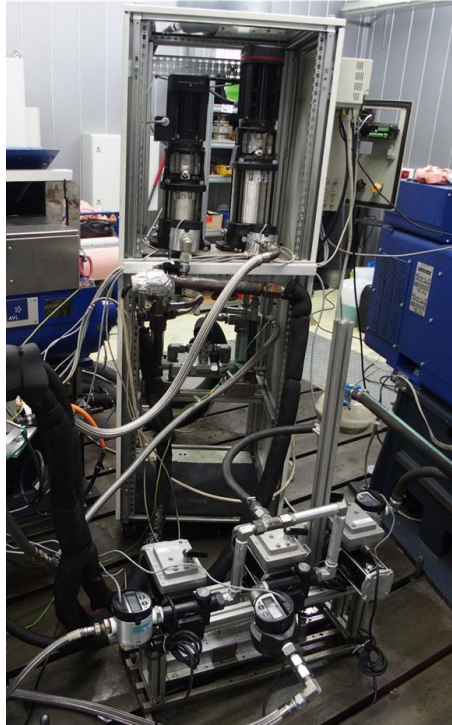

# Power converter test results

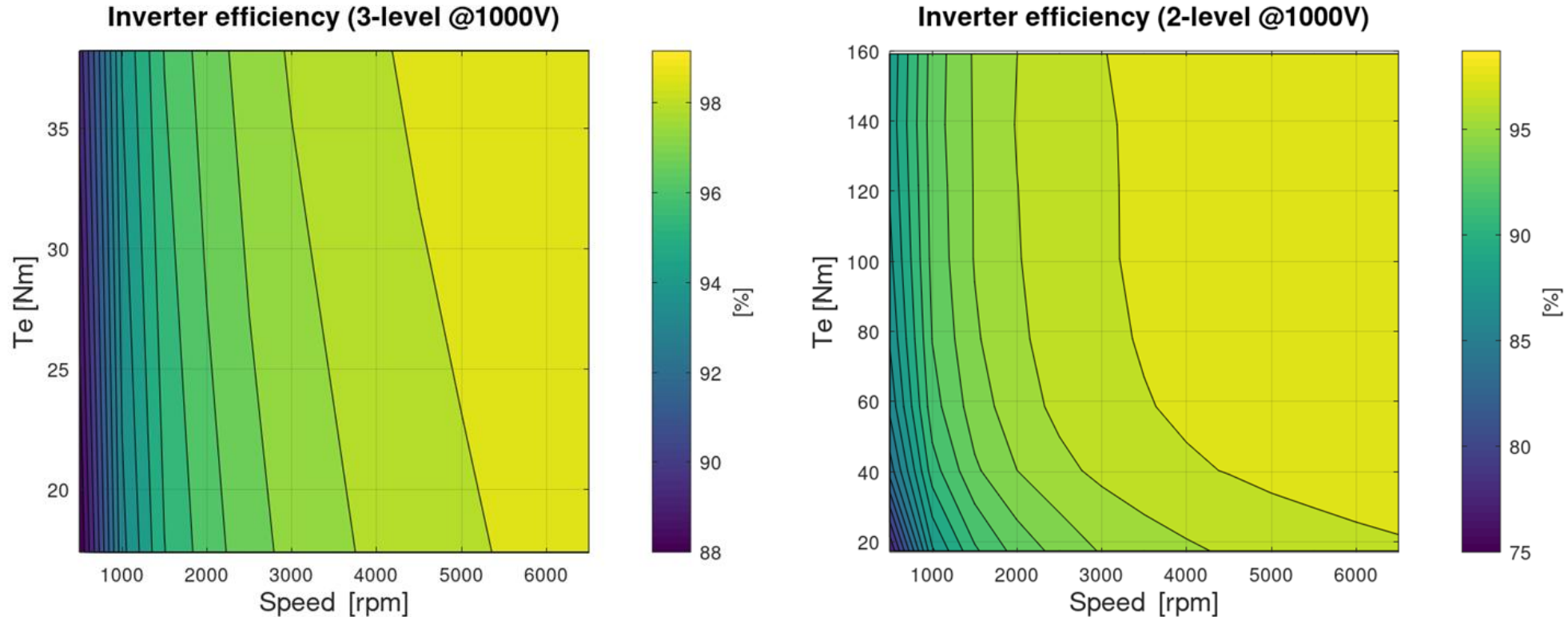

## TC003- Efficiency Map

### Inverter test - Measurement of loss, efficiency and conversion rate

Test performed on e-axle assembly (IMD + gearbox)

Torque range: -160 Nm ÷ 160 Nm

Speed range: 0 ÷ 6500 rpm

Voltage level: 800V (2L & 3L) and 1000V (2L & 3L)

Operation mode: 2L (0 ÷ 40 Nm), 3L (0 ÷ 160 Nm)

# E-axis test results

E-axis EFFICIENCY (800 V)

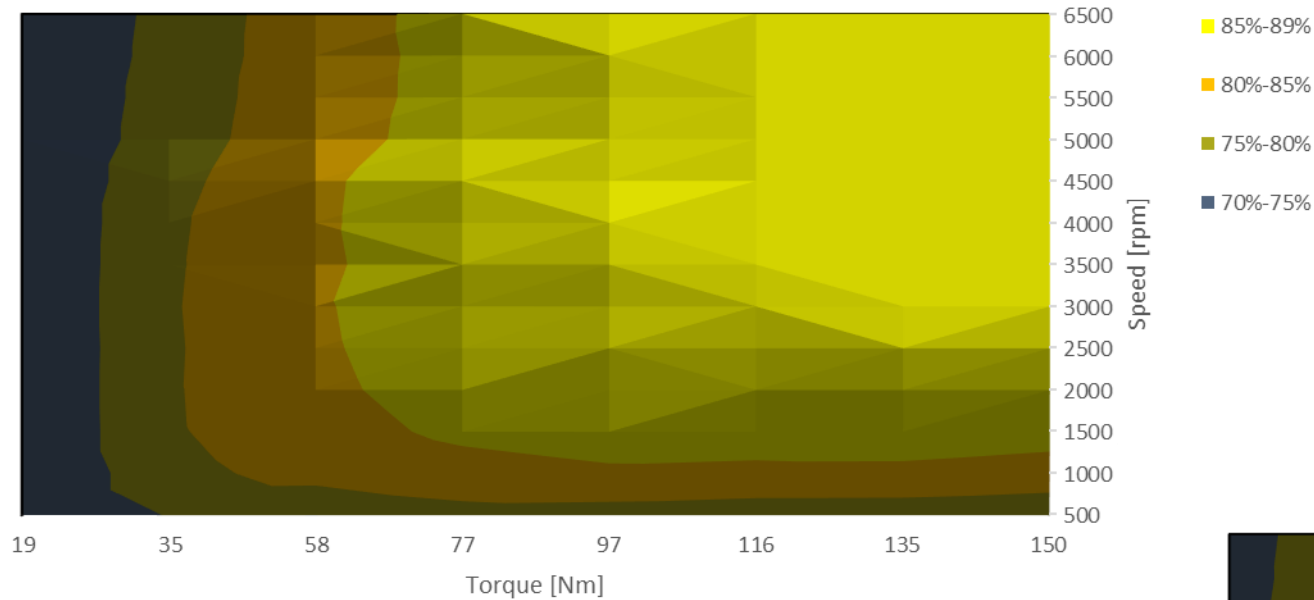

TC003- E-axis efficiency Map

E-AXLE EFFICIENCY 1000V

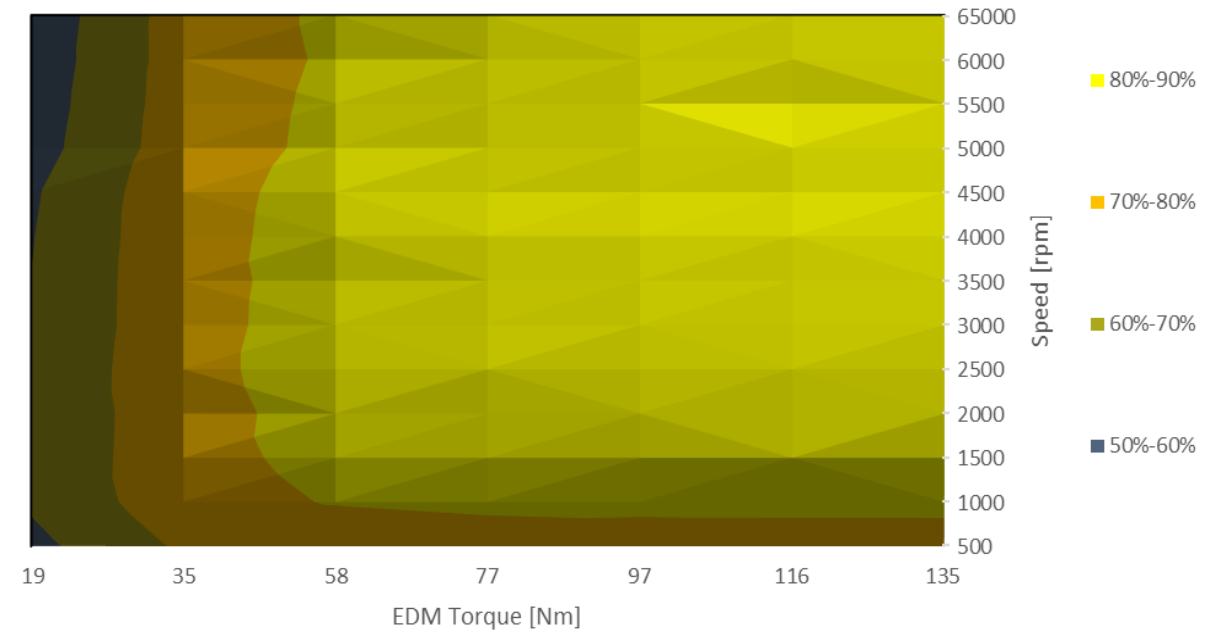

**Test performed on e-axis assembly (IMD + gearbox)**

**Torque range: -160 Nm ÷ 160 Nm**

**Speed range: 0 ÷ 6500 rpm**

**Voltage level: 800V (2L & 3L) and 1000V (2L & 3L)**

**Operation mode: 2L (0 ÷ 40 Nm), 3L (0 ÷ 160 Nm)**

# E-axle & Power converter test results

## TC003- E-axle efficiency Map + comparison

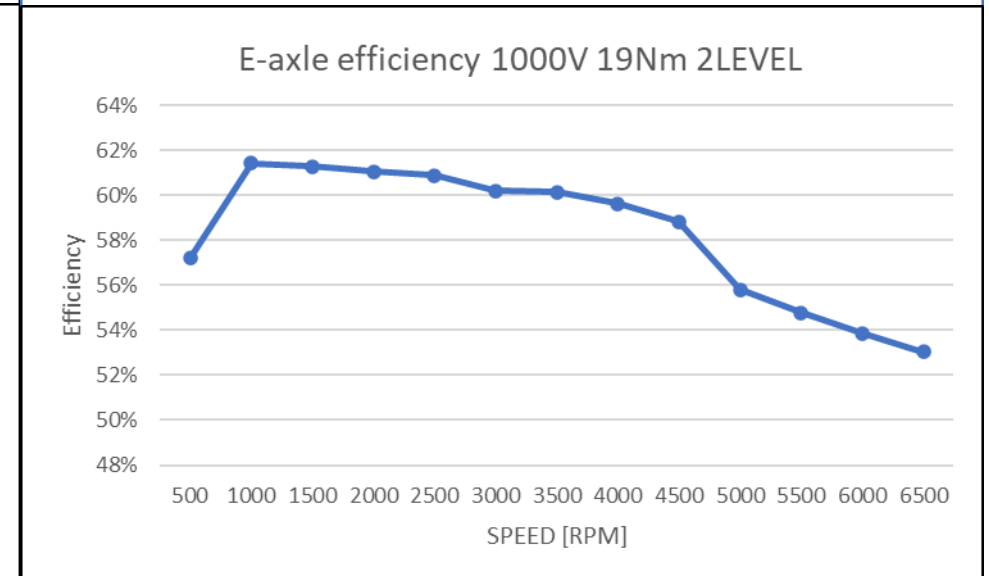
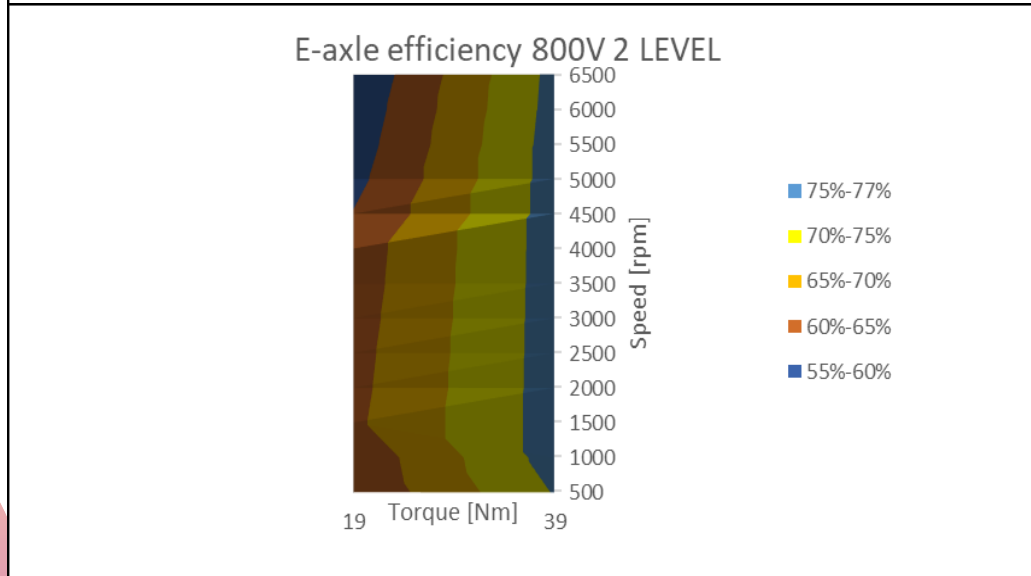
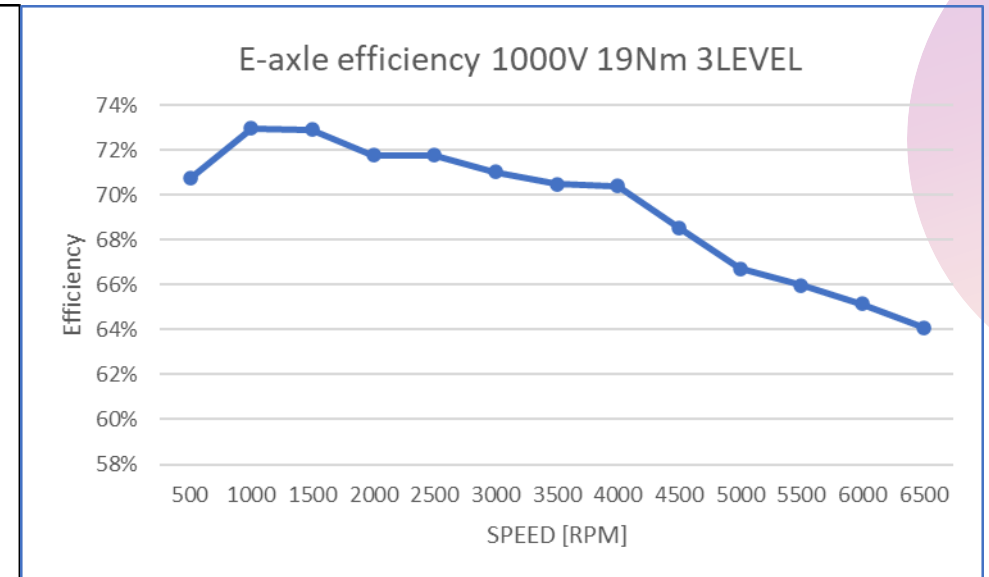
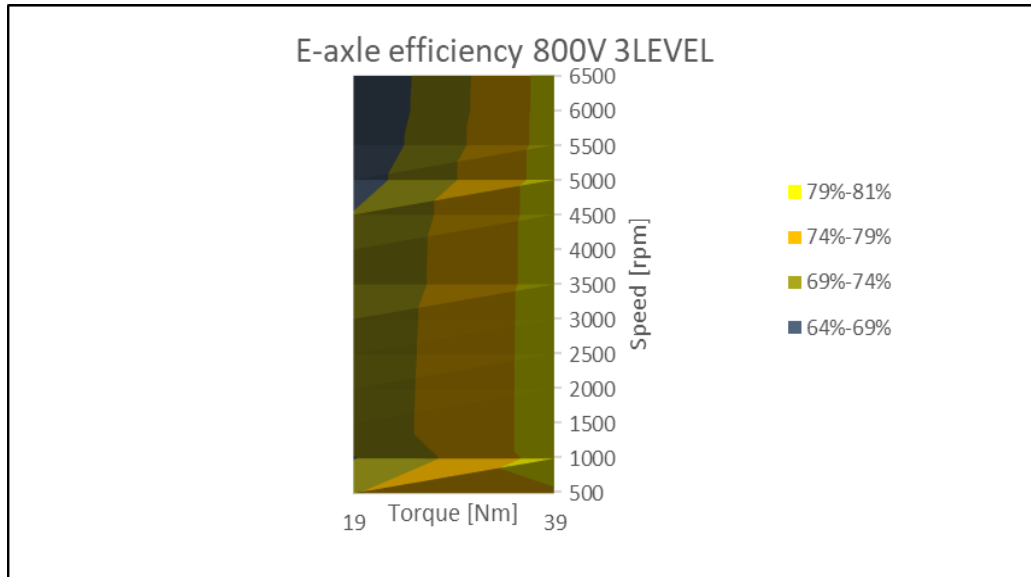

# Gearbox test results

GEARBOX EFFICIENCY 1st gear (positive torque)

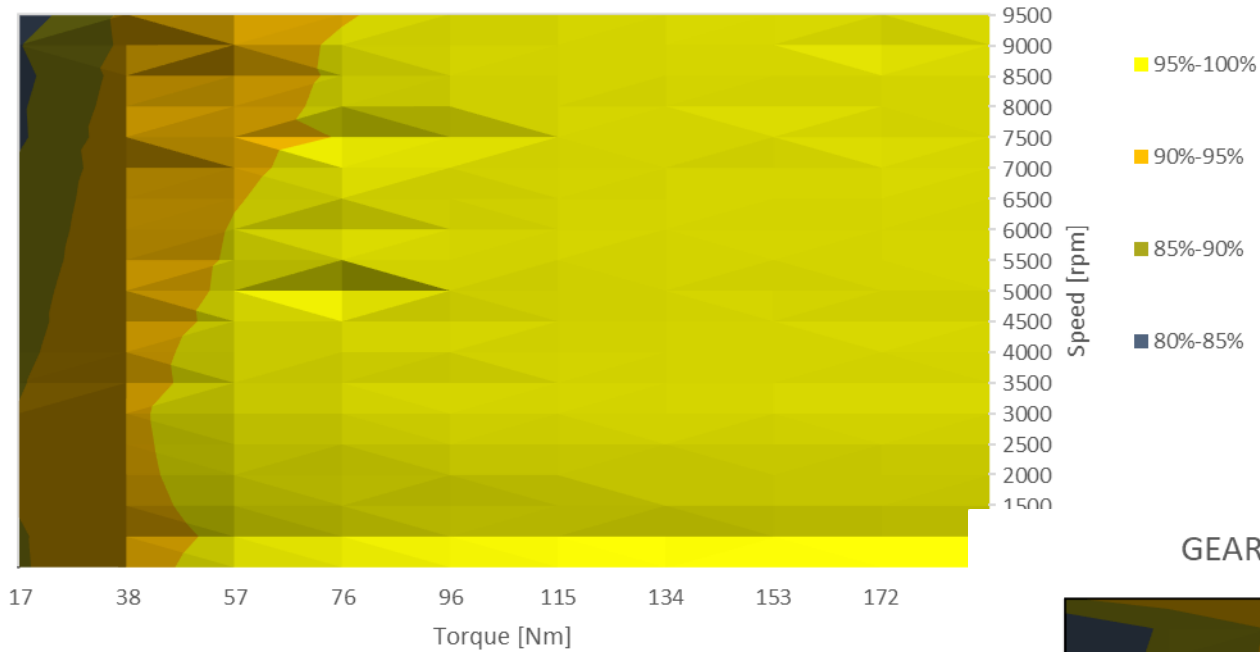

## TC003- Gearbox efficiency Map

GEARBOX EFFICIENCY 1st gear (negative torque)

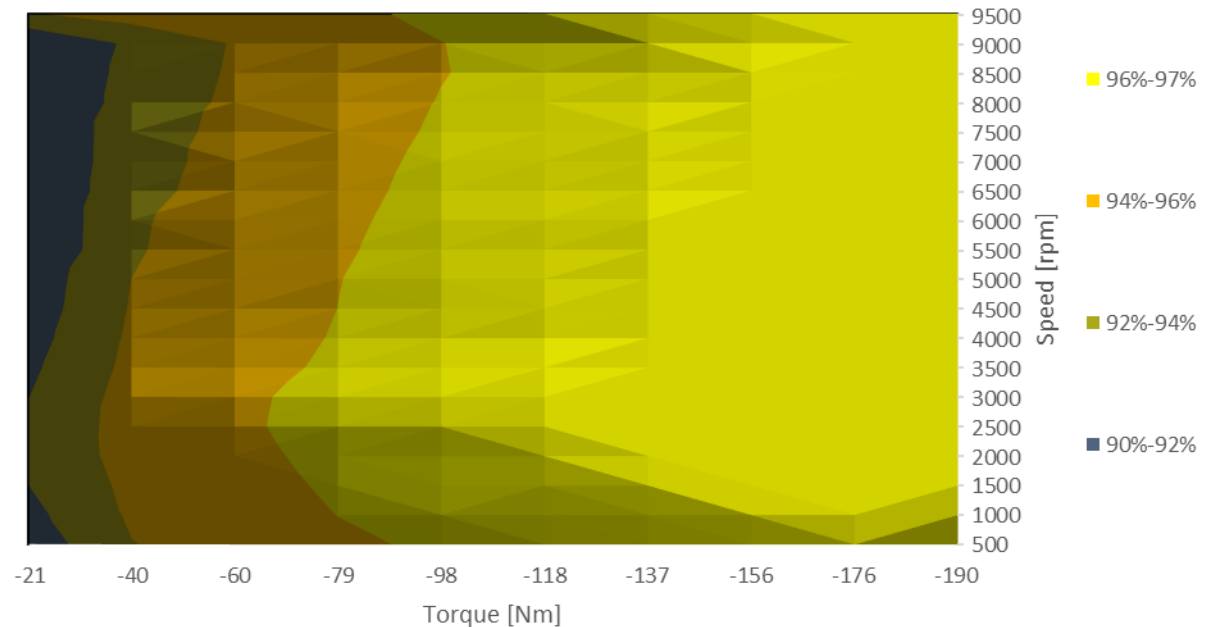

**Test performed at:**  
**Torque range: -190 Nm ÷ 190 Nm**  
**Speed range: 0 ÷ 9500 rpm)**

# SUMMARY OF KEY ACHIEVEMENTS

| KPI Target  | Status                    | Key Results & Observations  |
|---|---------------------------|---|
| <b>KPI-1: -40% Thermal Losses</b>                     | <b>Achieved</b>           | Validated reduction of 39-70% in simulations vs. conventional SiC converters.   |
| <b>KPI-2: 175°C Operation</b>                         | <b>Limited</b>            | Limited to 125°C due to current WBG encapsulation and GaN chip constraints.   |
| <b>KPI-4: -50% Size (Volumetric power density)</b>    | <b>Achieved</b>           | High-power converter: 97.66 kW/L. (Target 100 kW/L)<br>Integrated IMD: 36.54 kW/L (Surpassed target 33 kW/L ).                          |
| <b>KPI-5: -30% Weight (Gravimetric power density)</b> | <b>Partially achieved</b> | IMD: 5.58 kW/kg (Target 5 kW/ kg).<br>Inverter: 27.8 kW/kg (Target 50 kW/kg) .Modular design prioritized for repairability/circularity. |
| <b>KPI-6: -15 dB EMI Noise</b>                        | <b>Achieved</b>           | Confirmed experimentally on low-power unit via CB-PWM modulation.   |
| <b>KPI-7: -30% Failures</b>                           | <b>Achieved</b>           | Detection Accuracy: 100% (Temp/Volt), 94% (Abnormal Motor Vibrations.), 90% (IMD Thermal Models).                                       |

# The main achievements of RHODaS

- **Hybrid Converter Development:** *Development of a hybrid T-type converter based on SiC and GaN.*
- **Modulation Strategy:** *Design of novel modulation techniques to optimise the converter's high-frequency operation (improving efficiency, EMI, and harmonic distortion).*
- **Cloud Platform:** *Creation of a cloud-based platform for real-time validation of converter performance and predictive maintenance.*
- **High-Density IMD:** *Design of a high power and gravimetric density Integrated Motor Drive (IMD) incorporating the new converter.*
- **Testing & Standardisation:** *System testing based on the latest automotive standards, including proposals for regulatory updates to accommodate testing for this new generation of converters.*

# Mid to long term expected impacts of the project



# TECHNOLOGICAL & ENVIRONMENTAL IMPACT

## SUSTAINABILITY

- **Eco-Design:** Prioritized components using Environmental & Criticality Matrices. Targeted 30% GWP reduction via LCA screening (ISO 14040).
- **Circularity:** Modular design allows individual phase/component replacement, significantly extending product life and reducing e-waste.

## ECONOMIC

- **Reduced O&M Costs:** Predictive maintenance enabled by the Digital Twin and DSS is expected to lower operation costs by ~20%.
- **Efficiency:** >98% efficiency directly translates to lower energy consumption and longer range for heavy-duty logistics operators.

# SOCIETAL IMPACT & POLICY CONTRIBUTION

- **EU Green Deal Support:** Directly contributes to the decarbonization of the heavy-duty transport sector, a critical pillar of EU climate goals.
- **Standardisation:** Activities adhered to and validated against ISO and ECE standards, paving the way for future regulatory frameworks in EV powertrains.
- **Skills Development:** The project boosts expertise in advanced Wide Bandgap (SiC/GaN) technologies and Digital Twin applications, training the next generation of engineers and researchers.
- **Future Research:** Identified needs for higher switching frequency operation (> 100kHz) will guide future EU-funded research topics.



#RTR2026



# THANK YOU

[piotr.bielaczyc@bosmal.com.pl](mailto:piotr.bielaczyc@bosmal.com.pl)  
[rafal.sala@bosmal.com.pl](mailto:rafal.sala@bosmal.com.pl)  
[luis.romeral@upc.edu](mailto:luis.romeral@upc.edu)  
[david.lumbreras@upc.edu](mailto:david.lumbreras@upc.edu)

- **Website** - <https://www.rhodas.eu/>
- **Zenodo online repository** - <https://zenodo.org/communities/rhodas/records?q=&l=list&p=1&s=10&sort=newest>
- **Multi-Stakeholder Platform** - <https://stakeholders.rhodas.eu/>
- **YouTube** - <https://www.youtube.com/channel/UCLMrqBT4cFKPQ9vFJgks2UA>
- **LinkedIn** - <https://www.linkedin.com/company/rhodas>
- **X** - [https://twitter.com/RHODaS\\_EU](https://twitter.com/RHODaS_EU)



With the support of

